

GaN系列紫外探测器 LD-G410-100T

UVA Sensor: LD-G410-100T

Features	Indium Gallium nitride based material
	Broad band UVA+UVB+UVC photodiode
	Photovoltaic mode operation
	TO-46 metal housing
	Good visible blindness
	High responsivity and low dark current



Applications	UV LED monitoring
	UV radiation dose measurement
	UV Curing

Specifications

Parameter	Symbol	Value	Unit
Spectral characteristics (25 °C)			
Wavelength of peak responsivity	λ_{\max}	410	nm
Peak responsivity (at 410 nm)	R_{\max}	0.265	A/W
Spectral response range	-	220~440	nm
UV/visible rejection ratio ($R_{\max}/R_{440\text{ nm}}$)	VB	$>10^4$	-
General characteristics (25 °C)			
Chip size	A	1	mm ²
Dark current (1 V reverse bias)	I_d	<1	nA
Capacitance (at 0 V and 1 MHz)	C	300	pF
Temperature coefficient	T_c	-0.1	%/°C
Maximum ratings			
Operation temperature range	T_{opt}	-40~85	°C
Storage temperature range	T_{stor}	-40~85	°C
Soldering temperature (3 s)	T_{sold}	260	°C
Reverse voltage	$V_{R\max}$	10	V

Spectral response

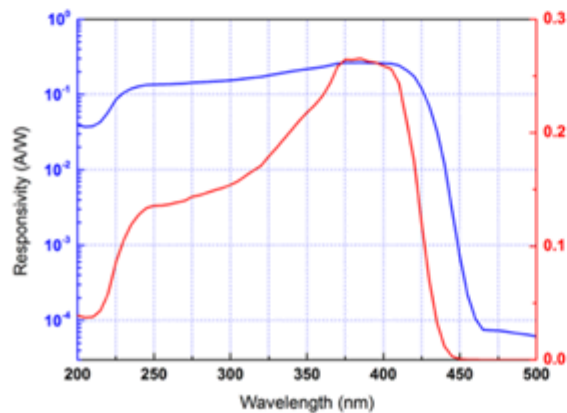

Package dimensions

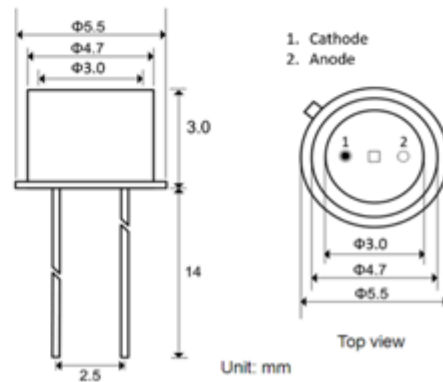

***Caution:** ESD can damage the device hence please avoid ESD.